

740450

## Nut- und Fasfräser aus VHM Carbide Slotting- and Chamfering Cutters - ACM

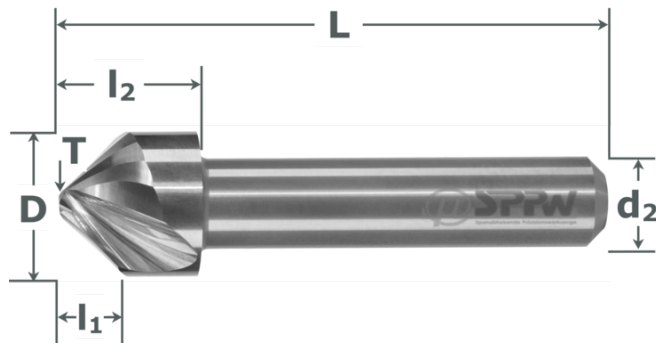

- Fas-Kantfräser für Alu-Composite
- ACM: Dibond®, Alcobond®
- Rechtsspirale, bessere Spanabfuhr
- Hohe Oberflächengüten
- Hohe Arbeitsgeschwindigkeiten
- Oberfläche poliert
- Creasing cutter for alu-composites
- ACM: Dibond®, Alcobond®
- RH-helix, improved chip removal
- High surface quality
- High working speeds
- Cutting edge and flute polished



VHM	mirror
R/R	z:2
DIN 6535HA	ACM



$\varnothing D$ h10	$\varnothing d2$ h6	L	l1	z	$\alpha$	l2	T	Art. No.	Stk/pce Euro	$\varnothing D$ h10	$\varnothing d2$ h6	L	l1	z	$\alpha$	l2	T	Art. No.	Stk/pce Euro
12	12	60	4,7	2	95°	--	2	740450121295	110,00	20	10	50	5,2	2	108°	20	2	7404502010108	152,00
16	10	50	6,1	2	95°	15	3	740450161095	133,00	20	10	50	3,7	2	135°	20	2	7404502010135	152,00